

2436/36 FRP-N / Tier 15

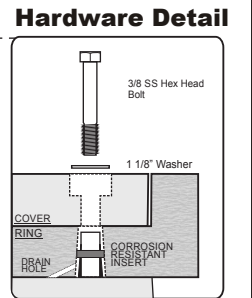
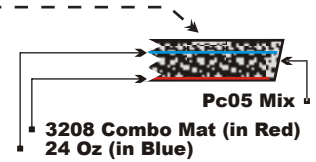
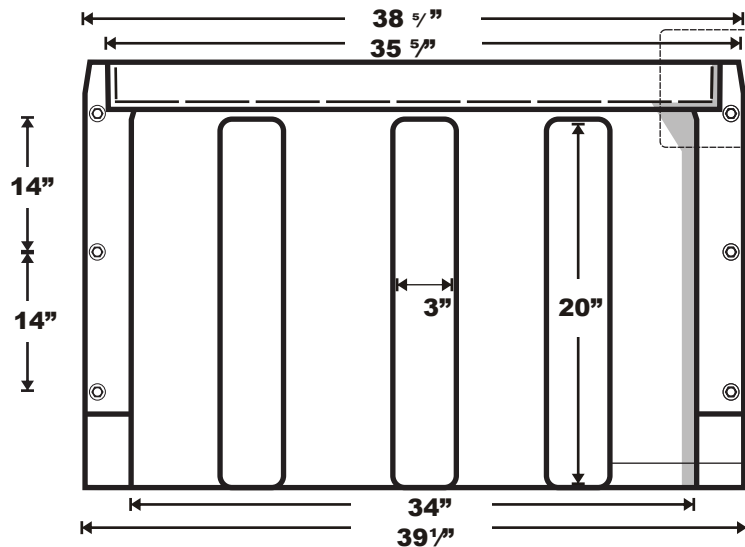
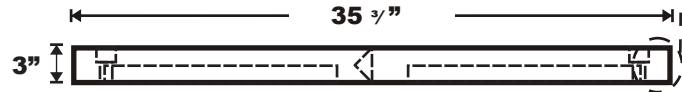
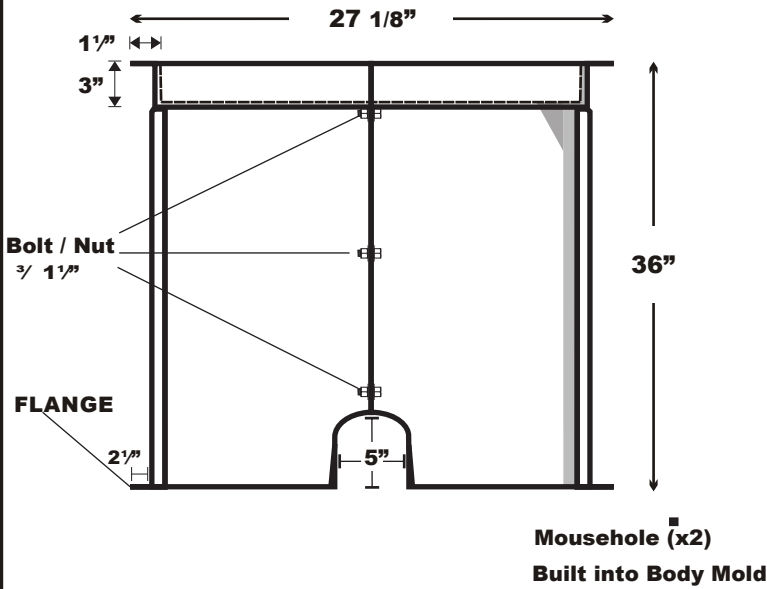
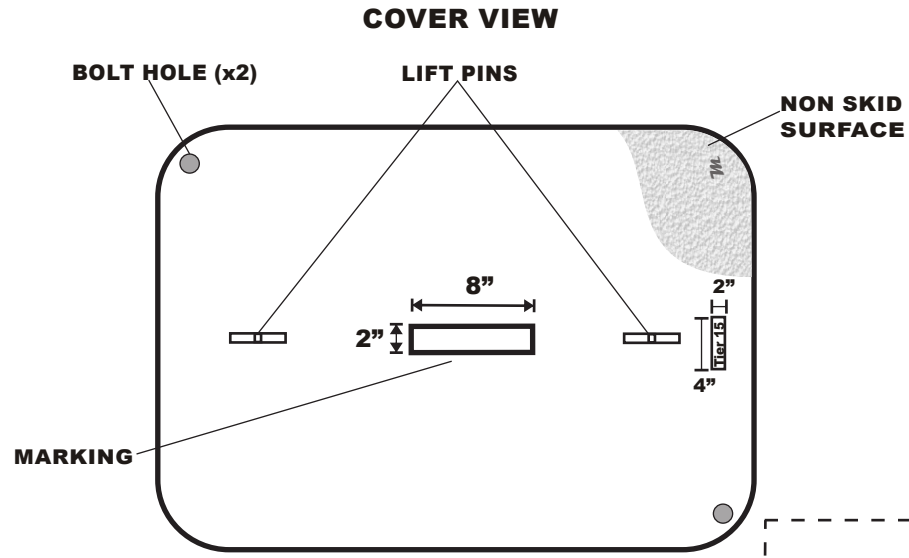
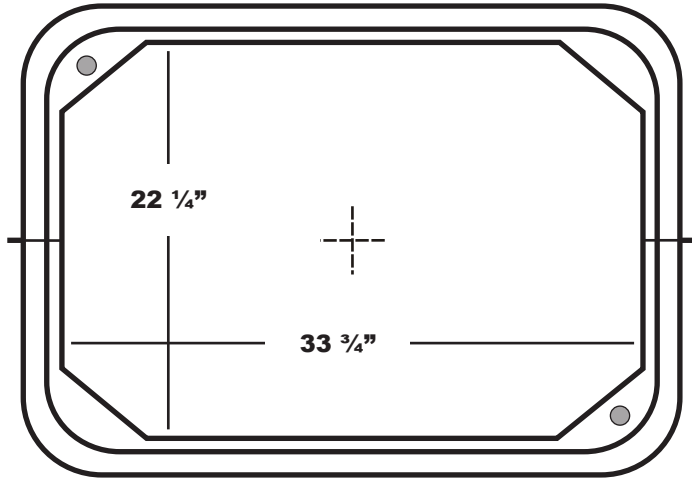

END VIEW

SIDE VIEW

Part Number 2436/36 FRP-N		
Body: FRP	Cover: Polymer Concrete	
Weight 215 lbs.	Tolerance +/- 1/8"	ANSI/SCTE 77 2013
October 17, 2014	File 2436/36 FRP-N	Tier 15 Rated
This product design is the sole property of Martin Enterprises. This design is NOT to be altered unless written permission is granted by Martin Enterprises.		

Martin Enterprises
 "Your Underground Enclosure Experts"
 ISO 9001:2008 Registered Firm
 QuEST Forum / TL9000 Registered

www.martinfrp.com